

PILOTS MANUAL – English

BETRIEBSHANDBUCH - Deutsch

MANUEL D'UTILISATION - Français

MANUAL DO PILOTO - Português

# Synergy 2



□ SOL SPORTS 2003

Version 12.2004

## **WELCOME TO THE SOL FAMILY OF PILOTS!**

We congratulate you on buying your new  
**SOL SYNERGY 2**  
and wish you many enjoyable hours of flying!

If you have any questions, feedback, suggestions  
or constructive criticism regarding any SOL product please do not hesitate to  
contact us.

We are happy to give help and advice.

SOL PARAGLIDERS  
SOL SPORTS IND. E COM. LTDA.  
RUA WALTER MARQUARDT, 1180  
89259-700 JARAGUA DO SUL - SC  
BRAZIL

PHONE : ++ 55 47 370 7753  
FAX : ++ 55 47 370 7114  
e-mail : [solsport@netuno.com.br](mailto:solsport@netuno.com.br)  
on the web: [www.solsports.com.br](http://www.solsports.com.br)

We are looking forward to hearing from you!

**PLEASE READ THIS MANUAL CAREFULLY AND  
NOTE THE FOLLOWING DETAILS:**

**At the time of delivery, this paraglider meets the requirements of the  
DHV, AFNOR and/or CEN norms.**

**Any alterations to the paraglider will render this certification invalid.**

**The use of this paraglider is solely at the user's own risk.**

**The manufacturer and distributor do not accept any liability.**

**Pilots are responsible for their own safety and their paraglider's  
airworthiness.**

**When purchasing this product, the pilot agrees to be in possession of a  
valid paragliding license.**

**This glider was not designed for school use.**

## SOL SYNERGY 2 Technical Data

Model		<b>S</b>	<b>M</b>	<b>L</b>	<b>XL</b>
Zoom Factor		<b>0,96</b>	<b>1</b>	<b>1,035</b>	<b>1,07</b>
Cell Number		<b>58</b>	<b>58</b>	<b>58</b>	<b>58</b>
Projected Wingspan	m	<b>9,38</b>	<b>9,77</b>	<b>10,11</b>	<b>10,45</b>
Projected Surface	m <sup>2</sup>	<b>20,95</b>	<b>22,73</b>	<b>24,35</b>	<b>26,02</b>
Projected A/R		<b>4,2</b>	<b>4,2</b>	<b>4,2</b>	<b>4,2</b>
Real Wingspan	m	<b>11,91</b>	<b>12,41</b>	<b>12,84</b>	<b>13,28</b>
Real Surface	m <sup>2</sup>	<b>25,18</b>	<b>27,32</b>	<b>29,27</b>	<b>31,28</b>
Real A/R		<b>5,64</b>	<b>5,64</b>	<b>5,64</b>	<b>5,64</b>
Line Diameter	m	<b>=</b>	<b>1,1-1,5-2,15</b>	<b>=</b>	<b>=</b>
Height	cm	<b>740</b>	<b>756</b>	<b>785</b>	<b>811</b>
Total Lines	m	<b>352</b>	<b>355</b>	<b>367</b>	<b>393</b>
Profile Max	m	<b>253</b>	<b>262</b>	<b>273</b>	<b>283</b>
Profile Min	m	<b>42</b>	<b>43</b>	<b>45</b>	<b>47</b>
Weight	kg	<b>6</b>	<b>6,3</b>	<b>6,7</b>	<b>7,1</b>
Legal Takeoff Weight*	kg lb	<b>60~80 132~176</b>	<b>75~95 165~209</b>	<b>90~110 198~242</b>	<b>105~125 220~275</b>
Sink Rate Min	m/s	<b>1,1</b>	<b>1,1</b>	<b>1,1</b>	<b>1,1</b>
Min Speed	km/h	<b>24</b>	<b>24</b>	<b>24</b>	<b>24</b>
Trim Speed	km/h	<b>39</b>	<b>39</b>	<b>39</b>	<b>39</b>
Max Speed	km/h	<b>54</b>	<b>54</b>	<b>54</b>	<b>54</b>
Glide Ratio		<b>9</b>	<b>9</b>	<b>9</b>	<b>9</b>
Places		<b>1</b>	<b>1</b>	<b>1</b>	<b>1</b>
DHV certification		<b>2</b>	<b>2</b>	<b>2</b>	<b>2</b>

Line specifications are detailed in the line plans. They are measured under a 5 kg (11 lb) load. The line lengths as specified in the line plans include the end loops.

The paraglider's details are printed onto the wing tip. The test flight date and pilot are written in the space provided.

## SOL SYNERGY 2 Materials

<i>Top &amp; Bottom</i>	Gelvenor LCN066 OL KS 49 g/m <sup>2</sup>
<i>Profiles</i>	Porcher Marine 9092 E29A H. Finish
<i>Reinforcements</i>	Diax 60 P Trilam Mylar
<i>Lines</i>	1.1 mm Cousin Dyneema 1.1 mm Cousin Superaram 1.5 (1.7) mm Cousin Superaram 2.15 mm Cousin Superaram
<i>Risers</i>	Fitanew 19 x 2.0 mm 1600 kg
<i>Carabiners</i>	Ansung Precision 4 mm 800 kg

## **SOL SYNERGY 2 Technical Description**

The **SOL SYNERGY 2** represents a perfect combination of performance and safety.

The **SOL SYNERGY 2** is a slim, elliptical wing with an evenly swept platform. The glider is constructed with 58 cells ensure a smooth top surface and an exact airfoil reproduction. The **SOL SYNERGY 2** has greatly reduced the number of lines, suspension points and the associated parasitic drag. This is especially important at high speed and results in an exceptional glide angle.

The profile of the **SOL SYNERGY 2** was selected from a large range of outstanding computer calculated airfoils. This airfoil was selected for its superior stability.

Large cross port vents allow an uninterrupted airflow inside the canopy and provide good reinflation characteristics without affecting the profile of the glider.

The **SOL SYNERGY 2** uses the latest in paraglider technology. Internal diagonal bands also help lower the number of lines and weight. Profile reinforcements are from carbon fiber reinforced Trilam Mylar. All stitching is internal which prevents snagged or torn threads.

The end result is a state of the art glider with excellent and precise handling, light reactions in extreme conditions and good passive safety.

### **Line Layout**

The **SOL SYNERGY 2** has five risers including the split A-riser. All lines are attached to their respective risers. The suspension lines consist of the upper cascaded top lines which are secured to the under surface, the middle lines and the main lines. The stabilizer lines (stabilo) are attached to the B-riser.

The lines of the **SOL SYNERGY 2** are made of a strong and stretch resistant sheath-core construction: the sheath consists of colored polyester with a core of white Polyethylene or beige Aramide. The main lines and main brake lines are 2.15 mm in diameter, the middle lines are 1.5 mm and the top lines above the cascade are 1.1 mm.

The control/brake lines are not suspension lines. They lead from the trailing edge of the canopy to the main control/brake line running through the pulley at the D-risers to the control handle.

The A-lines, A-risers and control lines are different colors for easier identification.

The line connections are triangular Maillon Rapides (quick links) fitted with plastic inserts to prevent any slipping of the lines.

The main control lines are attached to the control handles at their optimum trim point, which is also marked on the line. This adjustment allows sufficient brake to be applied during extreme flying situations and landing. While on the other hand, it assures that the canopy is not permanently braked. This position should not be altered.

## **Harness**

Any harness with a hang point at about chest height may be used with a **SOL SYNERGY 2**.

**Special note:** The hang point position changes the position of the brakes relative to the pilot's body.

The harness carabiner's distances are 40, 42, 44 and 46cm, for S, M, L and XL sizes respectively.

**Chest straps that are too tight can drastically effect the handling and may not actually contribute to higher safety. Make sure they are set at the correct distance.**

## **Speed System**

The **SOL SYNERGY 2** can be flown with a foot-operated speed system. However, the certification classification may change: check the certificate. An incorrectly fitted speed system results in the loss of certification.

The speed system changes the A, B and C-risers. In normal flight all risers have an overall length of 52.5 cm. When the speed bar is pushed down, the A and A1 with B-risers are shortened to 36.5 cm and 39.0 cm respectively. The C-risers change to 45.8 cm and the D-risers retain their original length.

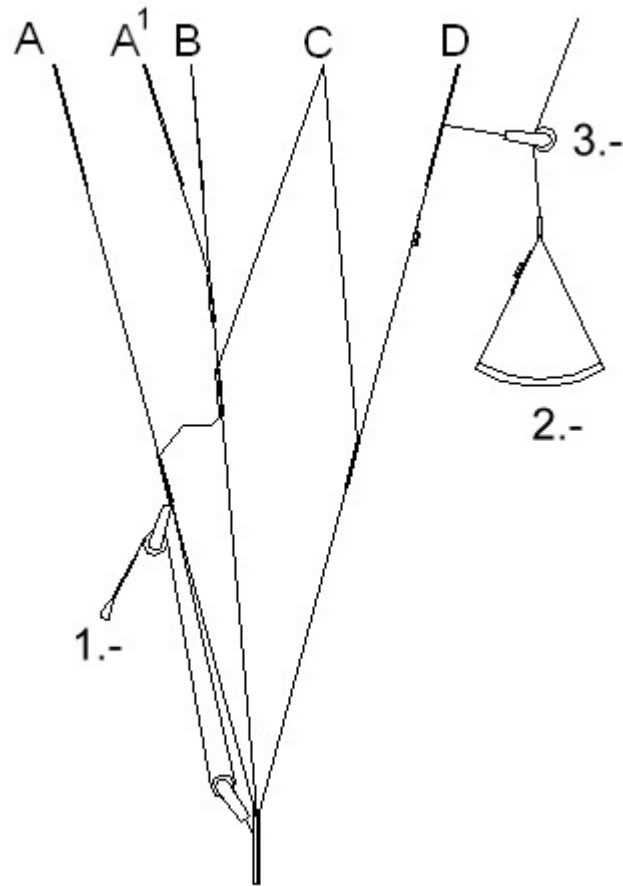

**1.-** Speed system

**2.-** Control Handle

**3.-** Brake pulley

Most modern harnesses have pulleys attached for fitting a speed system. If this is not the case, it is important to attach pulleys (sewn on tabs) in such a way that allows the pilot to maximize the power vector of his/her legs, without pushing back in the harness.

A quick link or clip with a very strong spring action is highly recommended. When doing a reverse start, the control lines can accidentally "clip in" to a carabiner with a weak spring action. This will obviously cause severe control problems.

The length of the cord leading to the speed bar should be such that it is easy to put your feet into the speed bar in flight and yet short enough to allow the full speed range. Use of two speed bars in a ladder fashion can enable you to reach the full range if your legs are not long enough.

Make sure both cords on the speed bar are of equal length to avoid putting a turn in the glider. Test your speed system for the correct length of cord on the ground first, with your harness and risers, before flying with it. The full range is reached when the two pulleys meet.

Make sure that the speed system is untangled and runs freely for operation before flying. To use the speed system, simply place your feet on the speed bar and push forward in a horizontal plane.

If a loss of back pressure from the speed bar on your legs is noticed, this is a warning that the canopy is probably about to collapse. Release the speed bar and thus the speed system immediately. With this "feeling" you may actually prevent most tucks from happening while using the speed system.

If a deflation does still happen, release the speed system immediately and correct the collapse as described in the section on **Deflations**. Do not release the control handles.

When flying into a head wind or through sink, for best glide angle, it is advisable to increase your speed by applying the speed system as long as conditions are not too turbulent.

Collapses and stalls are more dynamic the faster the canopy is flown. When using the speed system, the angle of attack is lowered. The airspeed is increasing and the canopy is becoming unstable. Therefore, do not use the speed system in turbulent conditions, close to the ground or near other airspace users. Do not use the speed system in any extreme maneuvers. Be careful.

## **Flight**

Your **SOL SYNERGY 2** will give you many hours of enjoyable flying.

### **Preflight Check**

A thorough preflight check is essential for any aircraft and the **SOL SYNERGY 2** is no exception. Having unpacked and laid out the paraglider in a horseshoe shape, the following checks must be made before flying:

The paraglider should be arranged in such a way that the A-lines in the center section of the canopy will tension before the ones at the wing tips. This ensures an easy and balanced launch. All lines and risers should be untangled and arranged in a way that they do not catch on anything. Special attention should be paid to the A-lines, which should run free and untangled from the A-risers (marked with red) to the canopy.

It is equally important to untangle the control lines so that they are clear and cannot get caught during launch. The control lines should run freely through the pulleys to the trailing edge of the canopy. Make sure the risers are not twisted. It is important that no lines are looped around the canopy. A "line-over" may have disastrous consequences during takeoff.

Before every launch, perform a thorough check of the lines, risers and canopy for damage. Do not launch in case of even the smallest damage.

## **Launch**

The **SOL SYNERGY 2** is easy to launch.

To make it easier to distinguish between the different risers, the A-lines and A-risers are different colors. So are the control lines and control handles.

When you are ready to take off, hold the A-risers and the control handles in your hands. Hold your arms stretched back and down as an extension of the A-lines. Before continuing, a final check of the canopy is important.

After the initial effort of inflation, keep applying forward pressure on the A-risers (pushing them forward not pulling down) until the pressure on the A-risers eases. The canopy should now be directly over the pilot's head. It is not necessary to get a running start with slack in the lines.

A good progressive run helps your **SOL SYNERGY 2** will inflate evenly and come up quickly. With the correct technique, the glider will not "over fly" you.

Always have a very small amount of brake applied so you can feel the glider and possibly correct for any drift in order to keep it above the your head. Moving your body to the center of the glider is the best method of correction if there is sufficient room.

The pilot looks up and checks that the canopy is fully inflated with no line tangles. Only after checking that the glider is fully inflated should the decision be made to continue launching.

The **SOL SYNERGY 2** is also easy to reverse launch. As this launch technique can be difficult and can result in the pilot taking off with twisted risers, it is recommended to practice the reverse launch on a training hill first.

## **Turns**

The **SOL SYNERGY 2** is very responsive. It has exceptionally easy handling and reacts instantly to any steering input.

A combined technique of weight shift and appropriate control line input is the most efficient turning method for any situation. The result is a turn that is wide and flat with minimal height loss.

The radius of the turn is determined by the amount of inside brake applied and weight shift. Using some outside break in turns, after initiating with weight shift, increases the efficiency and increases the outside wing's resistance to collapsing.

In case it is necessary to turn the **SOL SYNERGY 2** in a confined area at slow speeds, it is recommended to steer the canopy by releasing the brake on the outside of the turn while applying a little more brake on the inside of the turn.

**Special Note:** Pulling one brake too hard or too fast can result in the canopy entering a flat spin. Never turn the glider while flying at very slow speeds.

## **Thermaling & Soaring**

For the **SOL SYNERGY 2**, minimum sink is found with a little bit of brake pressure. Best glide is attained with no brake pressure applied. In turbulent conditions, the **SOL SYNERGY 2** should be flown with a small amount of brake applied. This improves stability by increasing the angle of attack of the canopy. The canopy should not rock back or surge forward but should remain above the pilot.

The pilot should increase speed by letting the controls up when entering a thermal (according to its strength) and should brake the canopy on exiting. This is part of basic active flying.

When soaring, a minimum height of 50 m (150 ft) above ground level is recommended for safety reasons. It is important to comply with the rules of the air, especially when many pilots share airspace close to a hill where last minute avoidance maneuvers are often not possible. With an active flying style, many potential collapses of the glider can be avoided.

## **Landing**

The **SOL SYNERGY 2** is easy to land. The final leg of the landing approach must be into wind and not marked by steep or alternating turns since can result in a dangerous pendulum effect near the ground.

During this final glide the paraglider should be decelerated slowly and at approximately 1 m (3 ft) above the ground the pilot should "flare" the canopy according to conditions. The glider may climb again, gaining height, if too much brake is used.

Strong wind landings require hardly any brake, if any at all. Use the C-risers to deflate the canopy after landing in strong winds not the brakes. Using the brakes will result in the pilot being lifted and dragged backwards.

## **Winching**

The **SOL SYNERGY 2** has no special winching characteristics, although a relatively low angle of attack and thus low tow tension should be maintained during launch.

## **Aerobatics**

The **SOL SYNERGY 2** is not designed for aerobatics.

## **Motor Flight**

The **SOL SYNERGY 2** has not been certified for motorized flight. However, the canopy has been used successfully by pilots wanting an absolutely safe glider. Before attempting motorized flight, consult with an instructor. Each combination of glider, motor and harness is different.

## **Extreme Flying Maneuvers**

Extreme flying maneuvers should only be carried out during safety training course (SIV or Instability Training) under proper instruction.

## **Asymmetric Deflations**

A negative angle of attack will cause the **SOL SYNERGY 2**, like any other glider, to tuck. If one wing collapses, straight flight is maintained by "correcting for direction" and braking gently on the inflated side. The pilot's "correction for direction" can be aided by a pumping out the deflation. A slow, long pumping action with the brake on the deflated side of the wing helps the canopy to re-inflate.

In case of a big tuck, this braking should be very gentle to avoid stalling the remaining part of the inflated glider. Weight shifting away from this collapsed side also helps, allowing less brake to be used and thus a greater margin of safety from the stall point.

If the pilot does not correct for direction, the canopy usually self-recovers in smooth air with less than one complete turn. In case the canopy does not recover by itself, the appropriate amount of brake must be applied to correct for direction and exit the turn. Otherwise the glider will enter a spiral dive.

If this spiral dive is entered, it should be exited by slowly and gently applying the outside brake until the canopy starts to retain a level bank angle. Just at this point, you pendulum under and in front of the canopy, it is vital to partially release the brakes. Control any surges and return to level flight. When the glider is flying straight and level again, "pump out" the collapsed side.

**Special Note:** If any spiral is not actively exited by the pilot, it will continue until impact with the ground. Strongly engaged spirals can cause loss of conscience due to high "G" forces induced.

## **Flat Spin**

A spin is induced when the pilot at full speed (DHV tests) or in very slow flight (AFNOR tests) pulls one brake line all the way down very hard and very quickly. During a spin the pilot turns relatively fast around the center section of the canopy while the inner wing flies backwards.

To recover from an unintentional spin, the brake/control line you have pulled down should be immediately released as soon as the situation is noticed so that the canopy may accelerate and return to its normal straight and stable flying position without losing too much height.

In case the spin is allowed to develop for some time, on exiting the **SOL SYNERGY 2** can surge forward on one side and a big asymmetric collapse can occur. If so, brake gently to stop the canopy from surging. It may be necessary to correct any deflations. Refer to the section on **Deflations**.

## **Wingover**

To induce a wingover, the pilot flies consecutive alternating turns which gradually steepen the bank angle. Too steep of an angle of attack will result in a collapse that may be quite dynamic.

**Warning:** A turn with more than a 60 degree bank angle is considered illegal aerobatics in some countries.

## **Symmetric Deflations (Frontal Stall)**

The **SOL SYNERGY 2** will usually re-inflate from a symmetric deflation (frontal stall) immediately. To help the recovery, both brakes should be moderately applied to open up the leading edge.

## **Line Over (Cravatte)**

If for any reason, lines are tangled or looped around the canopy during flight, do not over react. Maintain straight flight by gently correcting for direction. Check the

situation carefully and once the line or lines looped around the canopy are identified, pull them gently to untangle. Pumping of the brakes with a line over doesn't always work.

If a very large unrecoverable collapse and line over occurs, it may be possible to clear the problem by entry and safe recovery from a full stall. This should only be carried out if sufficient altitude is available. If insufficient height is available (300 m or 1000 ft), or if in any doubt, the pilot should strongly consider a reserve deployment.

## **Emergency Steering**

In case it is impossible to control the **SOL SYNERGY 2** with the control lines, the outer D-lines, D-risers or the stabilizer lines may be used to steer and land the canopy.

## **Rapid Descents**

By far the best technique is to fly correctly and safely so that you never have to descend rapidly.

## **Big Ears**

Pulling big ears with your **SOL SYNERGY 2** is easy. The outer cells of the wing tips may be deflated by pulling down on the separate A-risers simultaneously by approximately 30 cm (~12 in).

Keep hold of the control handles together with the A-lines. The canopy remains completely controllable through one sided braking or weight shift. It maintains straight flight but with an increased sink rate (up to approximately 4 m/sec or 787 fpm).

On releasing the A-lines, the canopy usually reinflates by itself or can be aided by a long pump on the brakes and holding them until the tips are clear. Be careful not to stall the canopy while clearing both wing tips at the same time.

## **Spiral Dive**

To enter a spiral dive with a **SOL SYNERGY 2**, the pilot must slowly apply more and more brake on one side to initiate an increasingly steeper turn.

During a spiral dive, the bank angle can be controlled by increasing or reducing the amount of inside brake. To exit, ease off the inside brake slowly and gently apply some outside brake. Continue turning until the glider has lost sufficient

amounts of energy. Watch for and dampen any surging. Allow sufficient height in the unlikely case that the glider continues for one or two turns.

Enter and exit slowly from a spiral dive. Never do these in turbulence or at too high bank angles. If done in strong winds, the pilot may drift off course.

Due to the rapid loss of height encountered during a spiral dive (maximum 20 m/sec or 4000 fpm) sufficient altitude is essential for this maneuver. Spiral dives can also create very high G-forces, placing high loads on the glider's structure and the pilot. Be careful not to overload the glider and yourself.

**Special Note:** Never do big ears in a spiral dive. DHV tests have proven that loads can develop higher than those used in certification tests. This could result in a catastrophic structural failure of the glider as fewer lines are taking these high loads.

### **B-line Stall**

To induce a B-line stall, pull both B-risers simultaneously by 15~20 cm (6-8 in). The airflow over the top surface is detached and the canopy enters a deep stall without moving forward. Farther pulling of the B-risers reduces the surface area and increases the sink rate to approximately 10 m/sec (2000 fpm).

On quickly releasing the B-lines, the airflow over the top surface becomes reattached and the canopy surges forward to return to normal flight. If the canopy does not recover, see the section on **Deep Stalls**.

If the B-risers are pulled too quickly or too far, the canopy can form a front horseshoe. To recover from this, apply both brakes gently to recover.

### **Deep Stall**

The **SOL SYNERGY 2** generally does not remain in deep stall and is self recovering when releasing any brake or riser input originally used to enter the stall.

In case the recovery from a B-line stall was not dynamic enough and the canopy remains in a deep stall, it is necessary to gently pull down both A- risers to reduce the angle of attack and reattach the airflow to the canopy.

### **Full Stall**

To induce a full stall, evenly apply full brakes on both sides and hold the brakes in that position with all your strength. The **SOL SYNERGY 2** generally flies backwards during a full stall and forms a front rosette.

The canopy must be stabilized (flying directly overhead) before letting out the full stall. If the canopy is not stabilized and the full stall is let out too early while the canopy still is sitting back, it will surge forward a long way. To recover from a full stall, both brakes must be let up evenly at a moderate speed (one second).

The **SOL SYNERGY 2** surges forward a little bit after recovering from a full stall. A collapse may occur if the surge is allowed to continue without pilot input.

An "asymmetric" recovery (one control released faster than the other) from a full stall is only used by test pilots to simulate a paraglider falling out of a thermal and must not be practiced by pilots. If not done correctly, this maneuver may result in a big dynamic collapse.

**Special Note:** All rapid descent techniques should be practiced in smooth air and with sufficient altitude so that they can be employed when necessary in extreme flying conditions. Full stalls and spins are to be avoided as the wrong recovery procedures, irrespective of the type of paraglider, may have dangerous consequences.

The danger of overcorrecting and overreacting exists during all extreme flight maneuvers. Remember, any corrective action must be gentle, steady and done with feel.

### **Looking After Your Paraglider**

Looking after your canopy correctly will prolong the life of your **SOL SYNERGY 2**.

#### **Storage**

Store the **SOL SYNERGY 2** in a dry space away from chemicals and UV light. Never pack up or store the glider when wet. This shortens the life of the cloth. Always thoroughly dry your glider before packing or storage.

#### **Cleaning**

Clean the paraglider if only absolutely necessary with water and a soft sponge. Do not use any chemicals or spirits for cleaning since these can permanently damage the cloth. Stubborn stains or animal droppings should be immediately removed, rinsed with water and then thoroughly dried.

#### **Repair**

Repairs should only be carried out by the manufacturer, distributor or authorized workshop.

## Packing

We recommend folding your glider using the “accordion” system. This system avoids folding the reinforcements and helps to maintain the launch and flying characteristics of your paraglider.

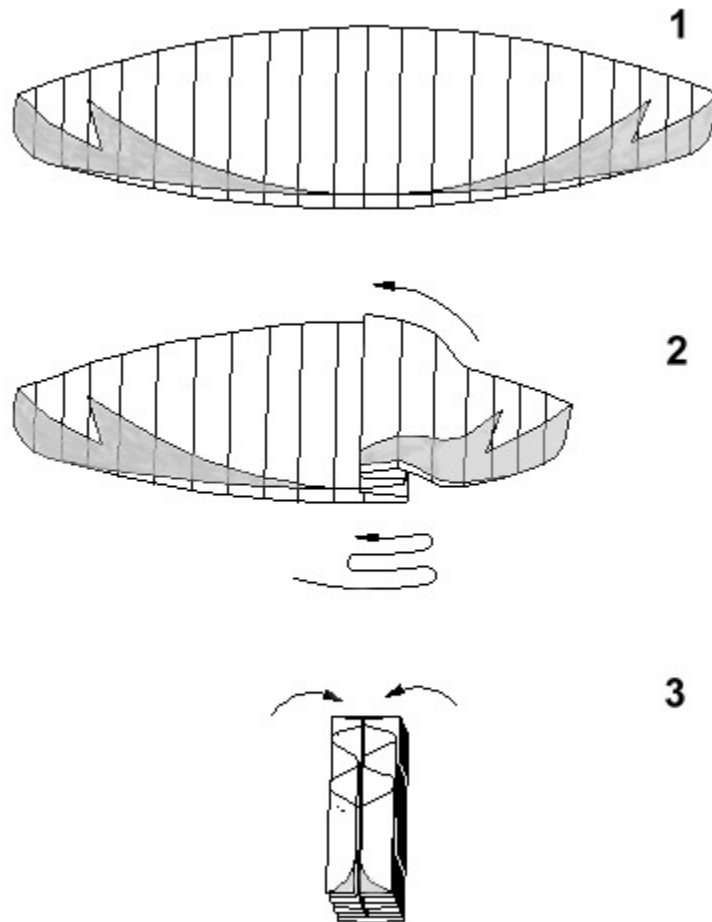

## Maintenance Tips

The **SOL SYNERGY 2** is primarily made of nylon. This cloth, like any synthetic material, deteriorates through excessive exposure to UV. It is recommended to reduce UV exposure to a minimum by keeping the paraglider packed away when not in use. Even when packed in the bag do not leave it in the sun.

Any over stretching of lines apart from the strain imposed during flight should be avoided as over stretching is irreversible. Make sure that the lines are not folded tightly.

Prevent the lines from catching on anything as they maybe over stretched. Do not step on the lines.

The control lines can chafe if badly tangled.

A line plan is enclosed in the glider manual or may be requested from the manufacturer or distributor.

Check line lengths after tree or water landings. This can stretch or shrink lines. Keep the canopy and lines clean as dirt may penetrate into the fiber and shorten the lines or damage the cloth.

Be careful not to allow snow, sand or stones to enter inside the canopy's cells. The weight can tear or even stall the glider. The sharp edges can destroy the cloth as well.

Uncontrolled strong wind takeoffs or landings can result in the leading edge of the canopy hitting the ground at high speed which may cause rips in the profile and damage the material.

Always remove a glider from the water by holding it only by the trailing edge.

Clean the paraglider with fresh water after contact with salt water.

Saltwater crystal can weaken line strength even after rinsing in fresh water. Replace lines immediately after contact with salt water.

Also check canopy material after water landings since waves can place uneven forces on the glider and cause the cloth to distort in specific areas.

Do not always fold the canopy symmetrically to the center cell as this can cause constant stress in the same area. The center cell should always be to the outside.

Remove any insects from the glider since certain types (i.e. grasshoppers) can produce an acidic substance that will eventually eat through the material.

An annual inspection of the **SOL SYNERGY 2** should be carried out by the manufacturer or distributor after every 100 hours of flying or once a year. This is a necessary term of the **SOL** warranty.

## **Conclusion**

The **SOL SYNERGY 2** is at the forefront of modern paraglider design.

You will enjoy many safe years of flying with your **SOL SYNERGY 2** if you look after it correctly and adopt a mature and responsible approach to the demands and dangers flying can pose.

It must be clearly understood that all air sports are potentially dangerous and that your safety is ultimately dependent upon you.

We strongly urge you to fly safely. This includes your choice of flying conditions as well as safety margins during flying maneuvers.

We recommend once more that you only fly with a reserve chute and helmet.

FLYING YOUR PARAGLIDER IS AT YOUR OWN RISK!

**SEE YOU IN THE SKY**

**Ary, Andre and the SOL Paragliding Team**

## **OVERALL PLAN – VUE D’ENSEMBLE – VISTA GERAL - GESAMTANSICHT**

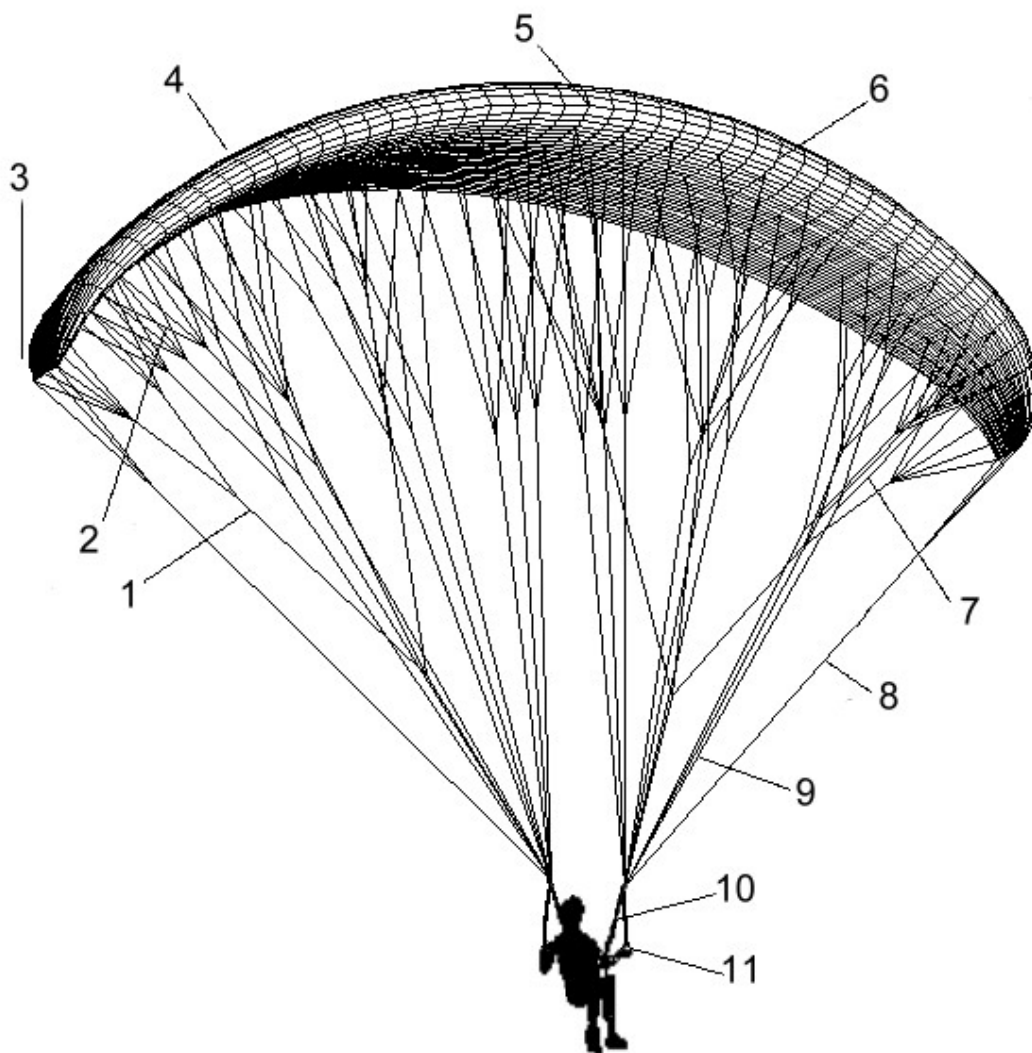

<b>Nr.</b>	<b>English</b>	<b>Français</b>	<b>Português</b>	<b>Deutsch</b>
	<b>Overall Plan</b>	<b>Vue d’ensemble</b>	<b>Vista Geral</b>	<b>Gesamtansicht</b>
1	Brake lines	Suspentes de frein	Linhas de freio	Bremsleinen
2	Top Lines	Suspentes hautes	Linhas superiores	Galerieleinen
3	Stabilo	Stabilisateur	Estabilizador	Stabilo
4	Trailing edge	Bord de fuite	Bordo de fuga	Austrittskante
5	Labels	Fiche technique	Etiquetas	Typenschild
6	Leading Edge	Bord d’attaque	Bordo de ataque	Eintrittskante
7	Middle Lines	Suspentes intermediaires	Linhas intermediárias	Mittlere Leinen
8	Stabilo Line	Suspente du stabilisateur	Linha estabilizador	Stabiloleine
9	Main Lines	Suspentes basses	Linhas principais	Stammleinen
10	Risers	Elevateurs	Tirantes	Tragegurte
11	Brake Handle	Poignée de frein	Batoque de freio	Bremsgriffe

# Line Plan

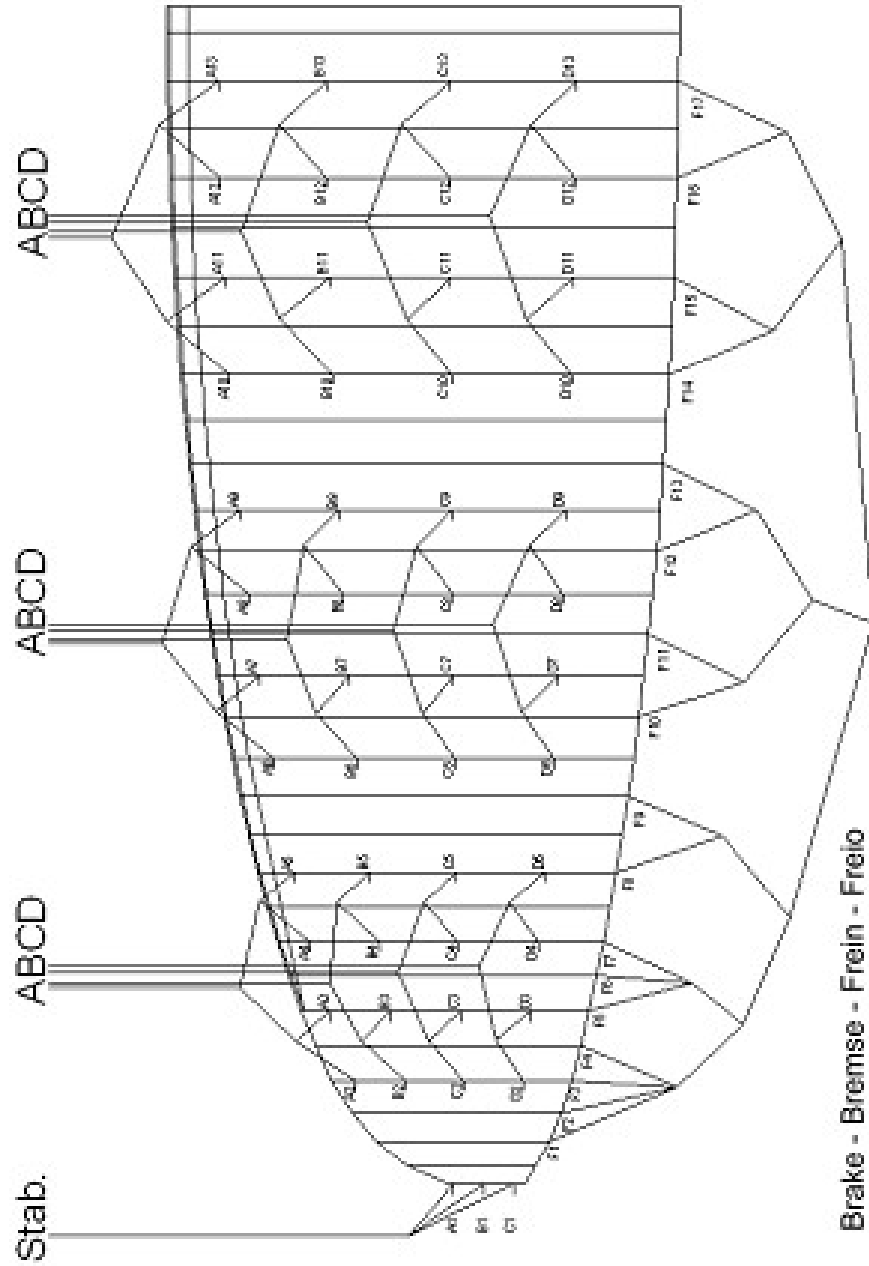



## Inspection Checklist

Model: \_\_\_\_\_

Owner: \_\_\_\_\_

Address/Phone: \_\_\_\_\_

Date of Inspection: \_\_\_\_\_

### Condition

Leading Edge Cell Openings \_\_\_\_\_

Dacron Re-Enforcements \_\_\_\_\_

Top Surface Panels \_\_\_\_\_

Bottom Surface Panels \_\_\_\_\_

Trailing Edge \_\_\_\_\_

Brake/Control Line Attach. Points \_\_\_\_\_

A Line - Upper \_\_\_\_\_

B Line - Upper \_\_\_\_\_

C Line - Upper \_\_\_\_\_

D Line - Upper \_\_\_\_\_

A Line - Middle \_\_\_\_\_

B Line - Middle \_\_\_\_\_

C Line - Middle \_\_\_\_\_

D Line - Middle \_\_\_\_\_

A Line - Main \_\_\_\_\_

B Line - Main \_\_\_\_\_

C Line - Main \_\_\_\_\_

D Line - Main \_\_\_\_\_

Brake/Control Lines \_\_\_\_\_

Internal Cell Walls & Cross Ports \_\_\_\_\_

Risers \_\_\_\_\_

Maillon Rapides \_\_\_\_\_

Brake/Control Handles \_\_\_\_\_

Comments: \_\_\_\_\_

---

## **Sol Warranty - Three Years or 300 Flight Hours**

Every paraglider produced from January 1, 2000 has a three year or 300 flight hour warranty, whichever comes first. Our development technology, the use of new materials and new manufacturing processes, makes this offer possible for our customers.

### Warranty Terms:

- 1) This warranty is valid for materials and mistakes on manufacturing processes being observed under predefined conditions.
- 2) This warranty is for every SOL paraglider AFNOR, CEN or DHV rated for leisure use only. This does not include professional equipment.
- 3) Warranty conditions:
  - 3.1) A three part form should be filled out correctly and sent to SOL Paragliders during the 30 day period after purchase. One copy is kept by the owner and another one is kept by the dealer.
  - 3.2) A flight log should be kept including the flight date, place and time.
  - 3.3) The equipment must be operated and maintained strictly following the instructions which are in the owner's manual. This includes the storage, folding, and cleaning of the glider.
  - 3.4) The maintenance and checking of equipment must be done only by the manufacturer or an authorized shop and a record should also be kept.
  - 3.5) The paraglider must be inspected annually or after every 100 flight hours if this amount of flights is reached before a year. Without this annual inspection, the paraglider loses its certification and the warranty.
  - 3.6) All shipping and handling expenses are paid by the owner.
  - 3.7) The final decision on exchanging or repairing a piece of equipment will be decided by SOL Paragliders. The owner must send to SOL Paragliders:
    - a) The paraglider to be exchanged or fixed and a copy of all inspections and a log of all flights.
    - b) The original copy of the SOL Paragliders warranty form.
- 4) This warranty doesn't cover:
  - a) Alteration of its original fabric, lines and risers.
  - b) Damage caused by chemical means, sand, friction, cleaning products or salt water.
  - c) Damage caused by inappropriate handling, accidents or emergency situations.
  - d) Damage caused by inappropriate operation of the paraglider.
  - e) Paragliders that have suffered any kind of alteration from its original form without SOL's official authorization.

**Thank you for flying the SOL SYNERGY 2!**